

Orbit Cuts off Utensil 軌道切斷器

Characteristic

Characteristic

- Guide apparatus for cutting a 90 degree angle exactly.
- Easy assembly on the workbench.
- Measure alignment metric and inch.
- Length stop: 1000mm.
- Burr-free cutting without loss.
- Shearing blade can be re-sharpened.
- Maintenance free.
- Labor saving due to better force transfer.

軌道切斷器 / 特性

- 九十度切割的前導裝置
- 易組裝於工作木台上
- 以公制及英制作量測校準
- 附帶卡尺可量測最大長度 :1000mm
- 無耗材的切割方式
- 裁刀可重覆研磨
- 免費維修
- 絕佳的省力切割方式

TSCU

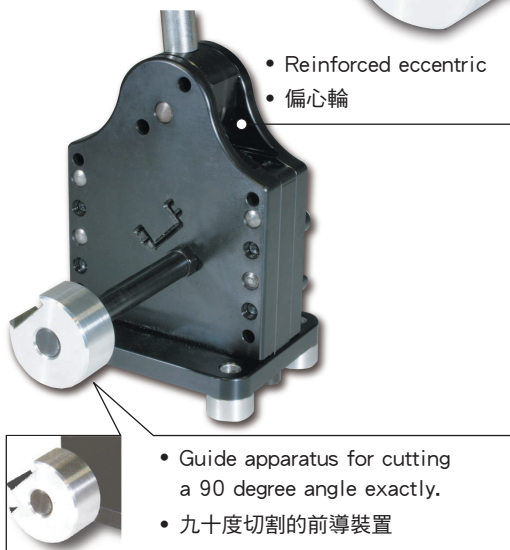
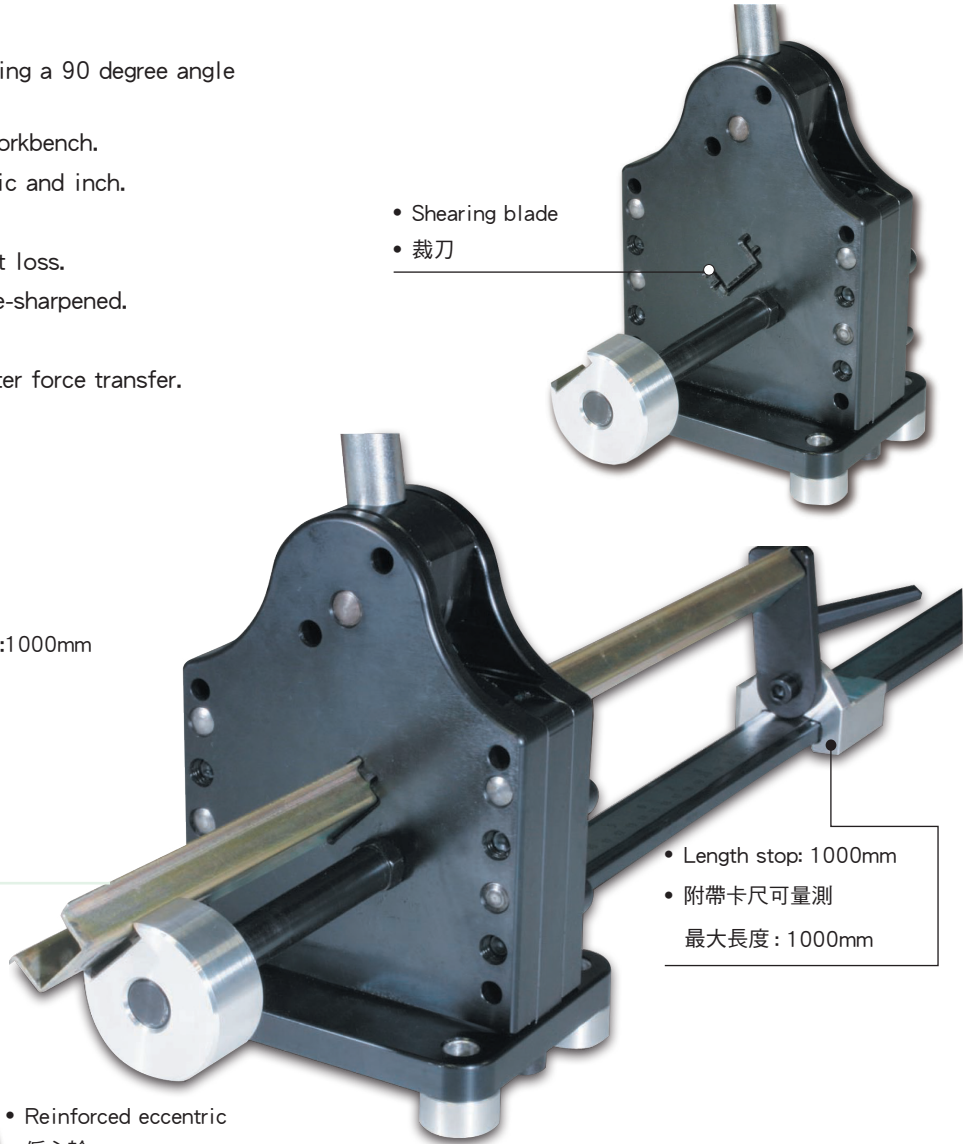

Carrier rails

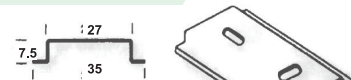

- Carrier rail 35mm / 7.5
ACC. to EN 50022
- 軌道寬度 35mm / 高度 7.5mm
符合 EN 50022 之標準



- Carrier rail 35mm / 15
ACC. to EN 50022
- 軌道寬度 35mm / 高度 15.0mm
符合 EN 50022 之標準